

ELECTRONIC IGNITION CONTROL UNIT



FOR

ALFA ROMEO MONTREAL

Technical features

Type of ignition:	high-energy capacitive discharge
Supply voltage:	10 V ÷ 18 V
Absorbed current:	<250 mA
Operating temperature:	<40°C (typical)
Environment temperature	-35° ÷ 90°C
RPM	tested at up to 9000 RPM
Dwell angle admitted	30° ÷ 70°
Protections:	supply pole reversal, output short circuit
Output current limit:	7,5 A
Weight:	900 g.
Shell	aluminium
Protection degree	IP66

Fitting instructions

N.B.: Failure to follow the fitting instructions voids all warranty rights

Before starting any operation disconnect the negative battery connection and reconnect it only once the installation has been completed.

During installation avoid touching the connection terminals of the TS control unit socket with your fingers.

Once the old control units have been removed, secure the new TS control units to the vehicle bodywork in the same position.

On each unit connect the female connector of the black wire (earth wire from the car wiring loom) to the male connector (1) on the metal shell of the control unit, above the black socket (2).

Insert firmly the three-wire main connector into the black socket (2) of each control unit.

Cover the connector/socket assembly with the protective rubber boot of the car wiring loom, blocking it on the ribbing (3) of the connector.

Now the installation is completed and the negative battery connection may be reconnected.

NEVER disconnect any connector from the control unit IF the car battery is connected!

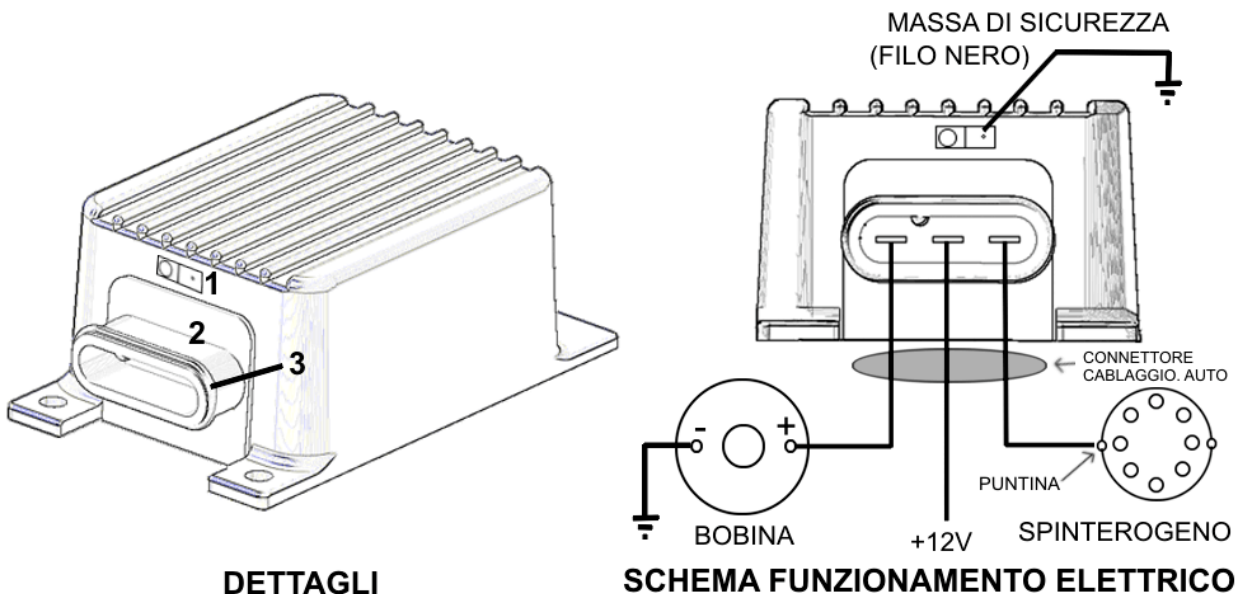

Details
wiring diagram
HT coil (bobina)
Distribiutor (spinterogeno)
Car wiring loom connector (connettore cab)
Safety earth (massa) (black wire)
Contact breaker point (puntina)

TERMS OF WARRANTY

A. Declaration of Limited Warranty

1. The Company AFRA s.a.s., guarantees to the final user presenting a valid proof of purchase, that the TS Electronic Ignition Control Unit is free from material and/or manufacturing defects for a period of two (2) years from the date of purchase if the proof of purchase is a sale receipt or one (1) year from the date of purchase if the proof of purchase is an invoice. This warranty is applicable only to the original final buyer (the user) and it is not transferrable. The conditions and limitations of the warranty hereto are set forth hereafter.

2. The limited warranty covers only defects emerging from the normal usage of the TS Control Unit and it is not applicable in case of:

- a. Inadequate or improper maintenance;
- b. Incompatibility due to application of the control unit on cars other than the one for which it has been designed;
- c. Unauthorized modification, alterations or improper use;
- d. wrong installation or negligence;
- e. usage in other than of the technical, electrical and environmental specifications of the control unit;
- f. improper preparation or maintenance of the point of installation;
- g. any other external cause not ascribable to defects of the control unit;
- h. defects or damage due to force majeure (including theft);
- i. defects and damage due to ordinary wear;
- j. defects or damage due to fall or collision;
- k. defects or damage due to over-feeding and/or electrostatic discharges.

3. If, during the period of validity of the warranty, the Company AFRA s.a.s. should receive notification of a defect covered by the warranty as well as the control unit it shall take care, at its own indisputable decision, of the repair or substitution of the product and shall return the product repaired or a replacement one within a reasonable period of time. The replacement control unit may also not be new, provided that it has features at least equivalent to those of the unit it is replacing.

4. This warranty is valid in any country in which the TS control units are distributed by the Company AFRA s.a.s. directly or through authorized dealers.

5. The Declaration of Limited Warranty hereto grants the customer specific legal rights.

B. Limitations to the warranty

1. NEITHER THE COMPANY AFRA S.A.S., NOR ANY OF ITS SUPPLIERS SHALL RECOGNIZE OTHER FORMS OF WARRANTY OF ANY SORT, EXPRESSED OR IMPLIED, IN RESPECT TO THE TS CONTROL UNITS. AFRA S.A.S. AND ITS SUPPLIERS SPECIFICALLY REFUSE (and the customer, by accepting the TS CONTROL UNITS, accepts also this refusal and waiver) ALL OTHER EXPRESSED OR IMPLIED WARRANTIES, INCLUDING -NOT EXCLUSIVELY- THOSE ARISING FROM THE SALEABILITY AND THE SUITABILITY FOR A PURPOSE OR PARTICULAR OR INTENDED USE AND THE WARRANTY FOR LATENT FAULTS, CONCERNING THE TS CONTROL UNITS.

2. In the case this Declaration of Limited Warranty resulted in contrast with the laws of the country in which the customer purchased the TS control unit, the Declaration of Limited Warranty shall be considered amended to meet the local laws and regulations. Pursuant to said local requirements, some of the limitations set forth in the Declaration of Limited Warranty hereto may not be applicable to the customer.

3. To the extent admitted by the local legislation, the right of recourse set forth in the Declaration of Limited Warranty hereto shall be the sole and exclusive right recognized to the customer.

C. Liability limitations

1. WITH THE EXCEPTION OF THE OBLIGATIONS SPECIFICALLY STATED IN THE LIMITED WARRANTY, IN NO CASE SHALL AFRA S.A.S. AND/OR ITS SUPPLIERS BE HELD LIABLE FOR:

a. compensation for direct, indirect, particular, accidental, consequent, foreseeable, unforeseeable or excess damage, if deriving from breach of contract, wrongful acts, criminal acts or any other legal case in point and also if there has been information regarding the possibility of such damage;

b. compensation for damage deriving from the loss of usage, of income and/or of related profits or from any interruption of the activity referable to the TS control unit.

2. Without prejudice for what stated above, any responsibility of AFRA S.A.S. and of its suppliers, for breach of warranty shall be limited to the amount paid by the customer for the faulty control unit in question.

3. To the extent admitted by the local legislation, the whole liability of AFRA S.A.S. and its suppliers and the sole compensation to the customer shall be the repair or replacement of any faulty product during the warranty validity period. AFRA S.A.S. and its suppliers offer no guarantee relative to its own product to third parties.

4. The customer shall bear all duties and taxes applicable to any replacement units, and related cost of freight, insurance, storage or other charges on returned products.

D. Assistance

1. Check that the TS control unit has been installed and configured following the instructions contained in the enclosed instructions.

2. Double-check the installation process of the control unit following the fitting instructions provided, to see if the problem may be solved without resorting to technical assistance

3. If the problem persists, please contact the dealer where the TS control unit was purchased or the Company AFRA S.A.S..

4. Should the TS control unit be returned, report the configuration adopted when in use and do not remove the identification labels. Pack the control unit in its original box and deliver it to the AFRA S.A.S. dealer where it was purchased, together with proof of purchase. It will be care of the dealer to forward it to AFRA S.A.S. Alternatively, if this option is not available, the customer may contact the Company AFRA S.A.S. which, upon delivery of a valid proof of purchase, will provide an RMA (Return Merchandise Authorization) and the instructions for despatch. DO NOT SEND RETURNS TO AFRA S.A.S. WITHOUT AN RMA CODE AND THE EXPRESS AUTHORIZATION BY AFRA S.A.S.



This product is in conformity with the EU Directive 2002/96/EC.

The symbol of the barred bin present on the device means that at the end of its useful life the product must be treated separately from household waste and disposed of at a designated centre for the separate collection of electric and electronic devices or returned to the dealer when purchasing a new equivalent device. The user is responsible for disposal of the device at the end of its life-cycle at the appropriate collection centre. The correct separate collection and the subsequent recycling, treatment and environmental-friendly disposal of the disused device contributes to the prevention of possible hazards for health and environment and favours the recycling of the materials forming the product. For further detailed information concerning the systems of collection available, contact the local waste disposal service or the shop where the item was purchased.

THE  ELECTRONIC IGNITION CONTROL UNIT

IS DISTRIBUTED EXCLUSIVELY BY:



AFRA S.A.S.
VIA CARDUCCI 36/38
20019 SETTIMO MILANESE (MI)
WWW.AFRA.IT